



**Operation manual  
Kalkwasserstirrer KS 5000**

**Reactor for the supply of reef aquariums with "Kalkwasser".**

With the purchase of this unit you have selected a top quality product. It has been specifically designed for aquaristic purposes and has been tested by experts. With this unit you are able to adjust the calcium level as well as the carbonate hardness in your seawater tank efficiently and to keep it on an optimum level.

## 1. Theory

### What is Kalkwasser?

The addition of a saturated solution of Calciumhydroxide was the first method for the supply of reef aquaria with Calcium. Powdered Calciumhydroxide is stirred into tap - or reverse osmosis water, the undissolved hydroxide settles down and the clear supernatant is slowly added to the aquarium. This clear solution is called „Kalkwasser“ or lime water. Because of its high pH of 12.4 a dripwise addition is required, to avoid a dangerous rise of the pH value in the aquarium. This solution attracts carbondioxide from the air. This results in the formation of calcium carbonate, that is hardly soluble and precipitates. The calcium content of the Kalkwasser decreases. **If the pH value from the Kalkwasser decreases from 12.4 to 12.2, the calcium content drops from 900 to 300 ppm. The entrance of carbon dioxide into the solution has to be avoided as far as possible.**

If you measure the carbonate hardness or the alkalinity of a Kalkwasser - solution, you will find a very high value. This value is however not caused by bicarbonate or carbonate ions, which can be used by the corals, but by hydroxide- ions. The hydrochloric acid in the alkalinity test cannot differ between these substances. In the aquarium the hydroxide reacts with dissolved carbondioxide to form bicarbonate ( $\text{OH}^- + \text{CO}_2 = \text{HCO}_3^-$ ) - if dosed slowly. If you dose the Kalkwasser too fast, the hydroxid may react with bicarbonate to form calcium carbonate - which is almost insoluble. As a result the alkalinity drops ( $\text{Ca}^{2+} + \text{HCO}_3^- + \text{OH}^- = \text{H}_2\text{O} + \text{CaCO}_3$ ). **For this reason, it is recommended to add the Kalkwasser during the night when you find the lowest pH value and the highest carbondioxid concentration.**

An important advantage of the so called "Kalkwasser-method" is the precipitaion of phosphates. By this process almost insoluble hydroxylapatite is formed:

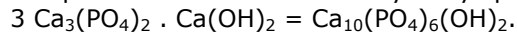

This substance will not dissolve under "normal" aquarium conditions.

The Kalkwasserstirrer is the automization of this method.

### 2. Working principle of the reactor

The unit is filled with tap or reverse osmosis water and calciumhydroxide ( **REEF LIFE Kalkwasser**, app 1 cup). The internal stirrer is started and the insoluble Calciumhydroxide forms a sediment at the bottom. Here, it is mixed with the inlet water. Now, you can pump water with a small external pump (e.g Niveaumat or dosing pump SP 3000) through the reactor. This pump is operated by a level controller or a time switch. The water flowing into the reactor is enriched with calcium as it is pumped through the Calciumcarbonate sediment. As the flow rate is slow, the undissolved Calciumcarbonate settles and you always have a clear solution of calciumhydroxide at the outlet. This principle allows a very compact construction. The reactor is hermetically sealed, carbon dioxide can enter the reactor only with the inflowing water. By this an intervall between 2 fillings of several weeks is possible. This interval depends first on the calcium requirement of the aquarium. For refilling the reactor, the used liquid is drained and fresh Calciumhydroxide is added. Afterwards, the reactor is filled with freshwater and the stirrer is started. If the solution has cleared up, the unit is ready to go.

#### Inlet:

The Kalkwasserstirrer is only supplied with by the top up water to replace the evaporated water in the aquarium. If the tap water quality is good ( low nitrate, low reverse osmosis unit ( Aqua Medic Standard 90). This refill water is placed in a reservoir ( cannister or glass tank)

Now, the inflow (3) can be connected to the reservoir via a suitable pump. We recommend to us a peristaltic pump (Dosing pump SP3000) or the Niveaumat with integrated level control.

## Control

We recommend to operate the Kalkwasserstirrer together with the electronic level control AB Aqua Medic **aquaniveau** or the **Niveaumat**. If water evaporates in the aquarium, it is replaced from the reservoir via the Kalkwasserreaktor.

If the level control is coupled with a time switch, the dosing of the Kalkwasser can be restricted to the night time.

It is also possible to run the reactor only with a time switch. To do this, you have first to check how much water evaporates per day and how long the pump in the reservoir needs to replace it. To avoid flooding, you should calculate a safety reserve and replace only two third of the evaporated water with Kalkwasser. This time is adjusted at the time switch. It is also possible to dose in several intervalls to avoid a pH increase. It ideal, if you add the Kalkwasser during the night, when the pH in the aquarium drops.

### 3. Set up and starting connections

The **AB Aqua Medic** Kalkwasserstirrer has 2 connections for flexible hose, 6/4mm (1/4") and 1/2") The first connection, the water inlet (7), with the feed pump. The water inlet is connected inside of the reactor to a tube, that directs the water right down to the bottom of the unit.

The 2 nd connection is the water outlet to the aquarium.(9). The end of the outlet tube should not be submerged, because it might clog in this case and the flow stops. **In every case the outlethose must be lower than the outlet of the KS 5000 (without pressure)!!!**

Filling of the reactor

Before refilling the reactor, remove the plug from the reactor and the refill pump from the mains. Open the bayonet (turn left). Take care not to lose the O- ring. undissolved residues of the Kalkwasserpowder should be removed. Clean the reactor.

To fill the reactor 3-4 cups (coffee cups) of Kalkwasserpowder are dissolved in approx 1 litre of freshwater and will for a milky liquid. This liquid is filled into the stirrer. Now the stirrer is filled up to the top with freshwater. If the reactor is already full, the outlet tube has to be directed into a bucket, so surplus water is drained. Now the stirrer with the motor can be mounted. As soon as the upper part of the liquid in the reactor clears up – a little turbidity is normal, the refill pump can be started again.

#### 4. Parts of the Kalkwasserstirrer

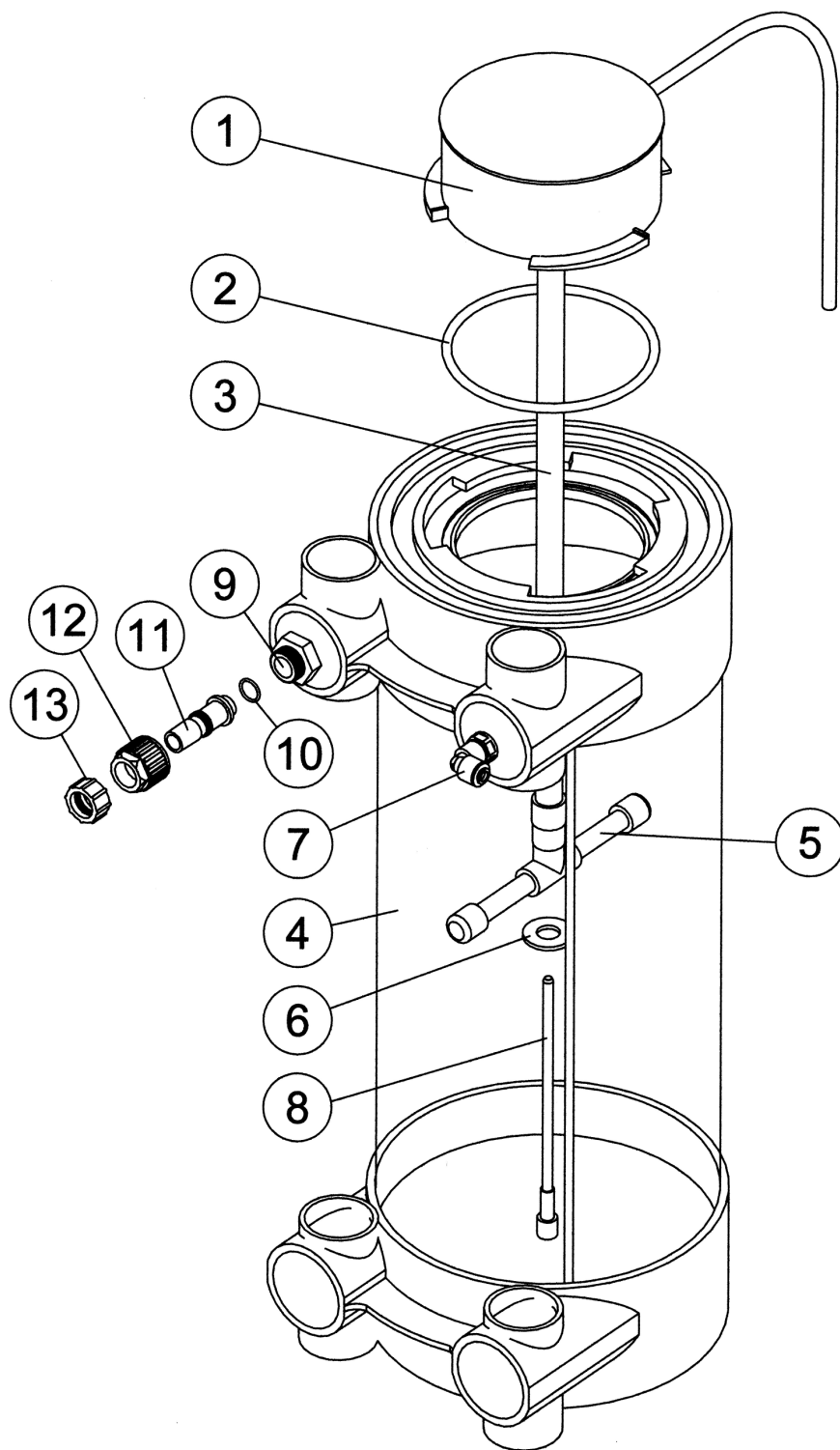

1. lid with motor
2. O-ring with bajonet
3. stirrer shaft
4. reaction vessel
5. stirrer
6. washer
7. water inlet
8. bearing for stirrer
9. water outlet
10. O-ring water outlet
11. hose connection water outlet
12. nut
13. nut for hose

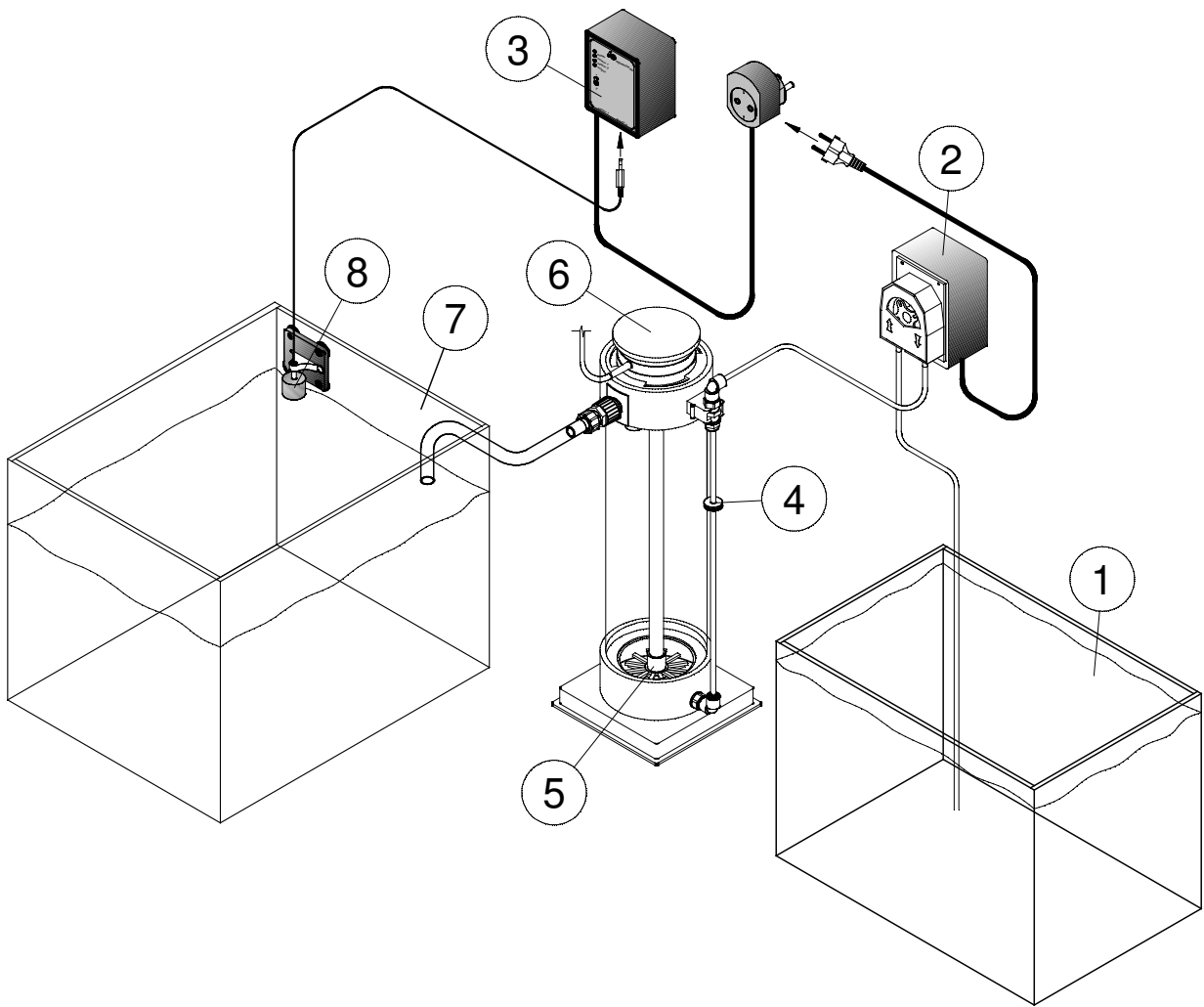

**fig 2: Set up of the Kalkwasserstirrer at the aquarium**

- |                        |                     |                 |
|------------------------|---------------------|-----------------|
| 1. reservoir           | 4. non return valve | 7. aquarium     |
| 2. Dosing pump SP 3000 | 5. stirrer          | 8. level switch |
| 3. aquaniveau          | 6. lid with motor   |                 |

The water is pumped by the dosing pump through the Kalkwasserstirrer and from here to the aquarium. The dosing pump is controlled by a Level control (aquaniveau). (Dosing pump and aquaniveau can be replaced by the Niveaumatt) As soon as water evaporates in the aquarium, the dosing pump is activated and water is pumped from the reservoir via the Kalkwasserstirrer into the aquarium.

## 5. Maintenance

The motor of the Kalkwasserstirrer has a lifetime of approx 10.000hr. After that, he has to be changed.

## 6. Kalkwasser and Calcium reactor

More and more of reef aquarists use the calcium reactor in combination with the Kalkwasserreaktor. The Calcium reactor produces free carbon dioxide, that is neutralised by the Kalkwasser. Phosphates, also those, that are produced by the Calcium reactor are precipitated by the Kalkwasser. However, you should avoid an overdosing of the calcium. Experiments have shown, that overdosing of bicarbonates and carbonates results in bleaching of red lime algae and corals do not fully open their polyps. The carbonate hardness (alcalinity) plays only a minor role in this process. Problematic is their quick dosage especially during daytime. The reason of this findings are not fully understood up today. In any case, a sufficient calcium supply of reef aquariums is one of the basic requirements.

Aquariums with low levels of calcium and high carbonate hardness (alcalinity) cannot be adjusted to the right calcium level neither with a Kalkwasserreaktor nor with a Calcium reactor. To raise the Calcium content for 50 ppm, the carbonate hardness has to be raised by 7°KH ( 2.5 mmol alcalinity) In this case, the only possibility is the addition of calcium chloride, e.g. **REEF LIFE Calcium** until the desired value is reached. This value is then kept constant with the Kalkwasserreaktor and the Calcium reactor.

## 7. Warranty

Should any defect in material or workmanship be found within 12 months of the date of purchase AB Aqua Medic GmbH undertakes to repair or, at our option, replace the defective part free of charge – always provided the product has been installed correctly, is used for the purpose that was intended by us, is used in accordance with the operating instructions and is returned to us carriage paid. The warranty term is not applicable on the all consumable products.

Proof of Purchase is required by presentation of an original invoice or receipt indicating the dealer's name, the model number and date of purchase, or a Guarantee Card if appropriate. This warranty may not apply if any model or production number has been altered, deleted or removed, unauthorised persons or organisations have executed repairs, modifications or alterations, or damage is caused by accident, misuse or neglect.

We regret we are unable to accept any liability for any consequential loss.

Please note that the product is not defective under the terms of this warranty where the product, or any of its component parts, was not originally designed and / or manufactured for the market in which it is used.

These statements do not affect your statutory rights as a customer.

If your AB Aqua Medic GmbH product does not appear to be working correctly or appears to be defective please contact your dealer in the first instance.

Before calling your dealer please ensure you have read and understood the operating instructions. If you have any questions your dealer cannot answer please contact us

Our policy is one of continual technical improvement and we reserve the right to modify and adjust the specification of our products without prior notification

**AB AQUA MEDIC GmbH - Gewerbepark 24 - 49143 Bissendorf/Germany**

- Technical changes reserved -